



# ***Installation Manual***

---

## ***78-88 Chevrolet G Body***

***Compressor Upgrade Kit - 123-2004***

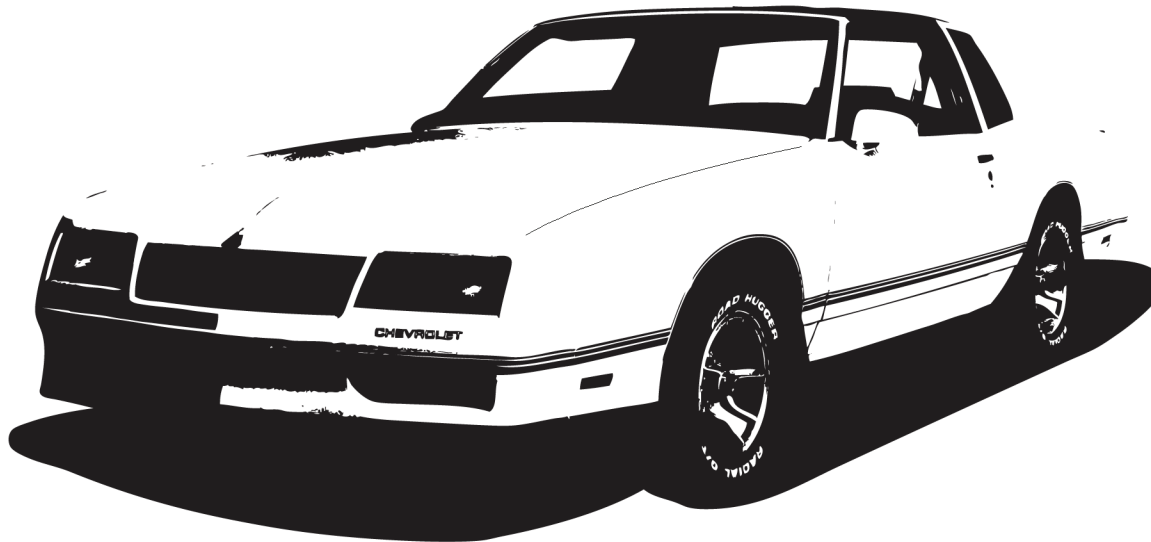



# ***Congratulations...***

**You have just purchased the highest quality, best performing A/C system upgrade ever designed for your Classic Vehicle.**

To obtain the high level of performance and dependability our systems are known for, please pay close attention to the following instructions. Our installation steps and procedures are derived from a long history of research and development and the combined experience achieved through thousands of successful installations (and feedback from customers like you). Please remember that our #1 goal is that you'll have a successful installation and a system that performs at a very high level for many years to come.

Before starting, read the instructions carefully, from beginning to end, and follow the proper sequence. On the next page you'll find a safety and general checklist that you should read before starting your installation.

Again, thank you from our entire staff.



## **PRE-INSTALLATION:**

- Before beginning the installation, check the shipping box for the correct components.
- **If your vehicle has been or is being modified, some procedures will need to be adjusted to fit your particular application.**
- A basic cleaning of the engine compartment before beginning will make things go more smoothly.
- Check condition of engine mounts. Excessive engine movement can damage hoses to A/C and/or heater.
- **DISCONNECT THE BATTERY FIRST**
- **DISCHARGE THE SYSTEM NEXT;** You will want to have your system evacuated of all remaining refrigerant according to local laws. An A/C service shop can handle this for you.
- **TOOLS/MATERIALS REQUIRED:** A Standard and Metric Socket Set, (A set of standard and metric ratcheting wrenches are suggested for the compressor installation), Magnet (Reach Tool), (2x) Medium Adjustable Wrenches, Flat Screwdriver, Wire cutter w/ crimper, Flat Blade Scraper, Tape or Caps, Schrader valve removal tool, and Spray Adhesive or Contact Cement (If replacing Evaporator).

**PLEASE NOTE! IT'S CRITICAL THAT ALL COMPONENTS ARE CLEAN AND FREE OF CONTAMINATION. DAMAGE TO COMPONENTS AS A RESULT OF CONTAMINATION WILL NOT BE COVERED UNDER WARRANTY.**

## **IMPORTANT NOTES:**

- Use one or two drops of oil (supplied with your kit) on **ALL** O-rings, and threads.
- All capped fittings **MUST** remain covered until actual connection of the fitting to prevent contamination.
- Use two adjustable wrenches on all O-ring connections, these should be tightened to 10-15 ft/lbs which is hand tight plus ¼ turn. Over tightening could cause splitting of the O-ring.
- Carefully thread fittings. Fittings will thread easily, therefore if there is resistance, back off and re-align to avoid cross-threading. Be careful not to over tighten.

**Should you have any technical questions, call us immediately, we will be glad to assist you.**

**Our toll-free number is listed on every page, we're here to help!**

**YOU CAN NOW BEGIN THE INSTALLATION...**



THESE ARE THE PARTS FOR YOUR COMPRESSOR UPGRADE KIT

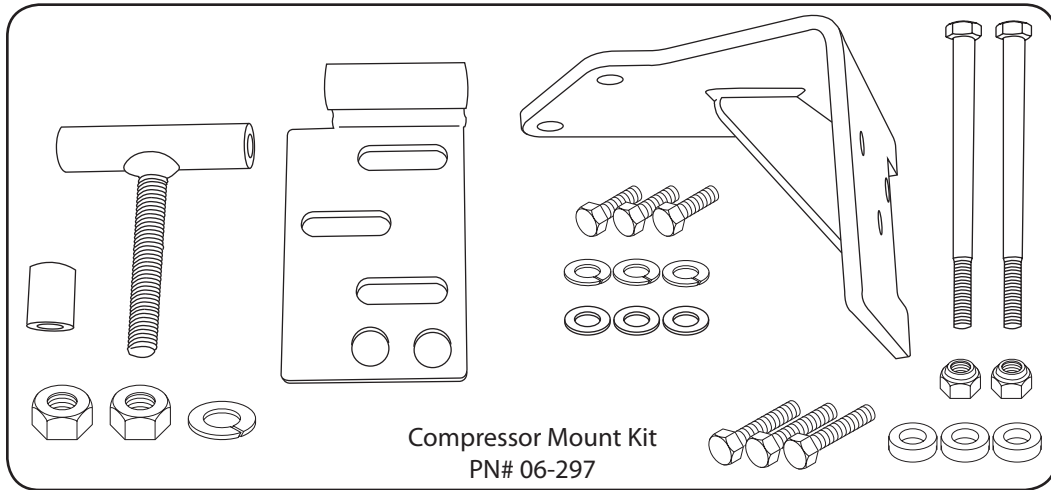

Compressor Mount Kit  
PN# 06-297

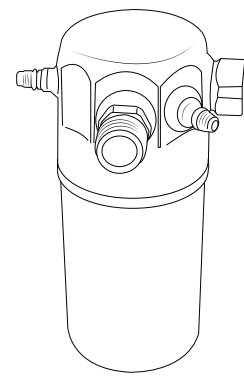

Accumulator  
PN# 12-215

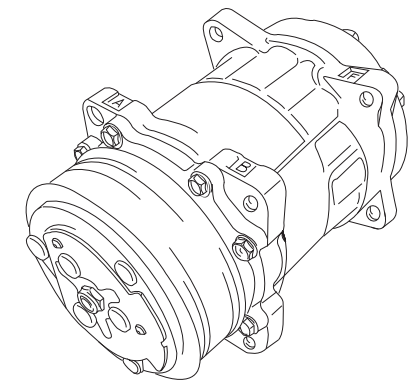

Compressor  
PN# 5-151

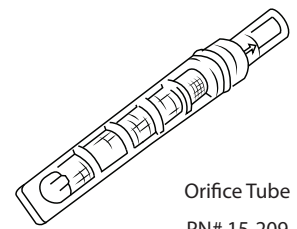

Orifice Tube  
PN# 15-209

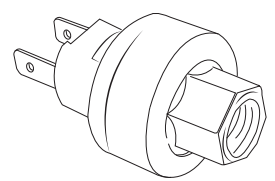

Clutch Cycling Switch  
PN# 16-200

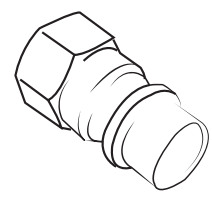

Straight  
(High Side - Red Cap)  
134a Adapter PN#  
14-201-1

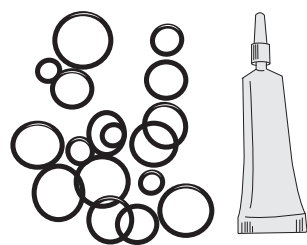

O-Rings and Lubricant Oil  
PN# 05-400

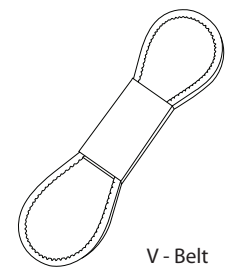

V - Belt  
PN# 10-201

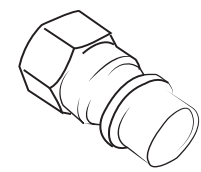

Straight  
(Low Side - Blue Cap)  
134a Adapter  
PN# 14-122-2

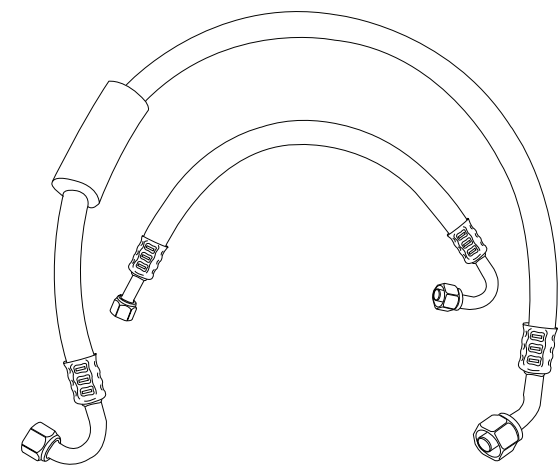

Suction Hose  
and Discharge Hose

## ACCUMULATOR REMOVAL

- Disconnect the plug from the pressure cycling switch (**Figure 1A**).
- Disconnect Suction hose from accumulator (**Figure 1B**).
- Remove the accumulator bracket hardware and small clamp connecting to the liquid line (**Figure 1C**)
- Disconnect the accumulator to evaporator outlet fitting (**Figure 1D**)
- Remove accumulator and retain brackets for re-assembly
- Disconnect the liquid hose (solid tubing) from the inlet fitting of the evaporator core (**Figure 1E**)
- Once the liquid line is disconnected you will see the orifice tube/ filter inside, this part will need to be removed (**Figure 2**).
- **Cover ends of evaporator fittings with tape to prevent contamination.**

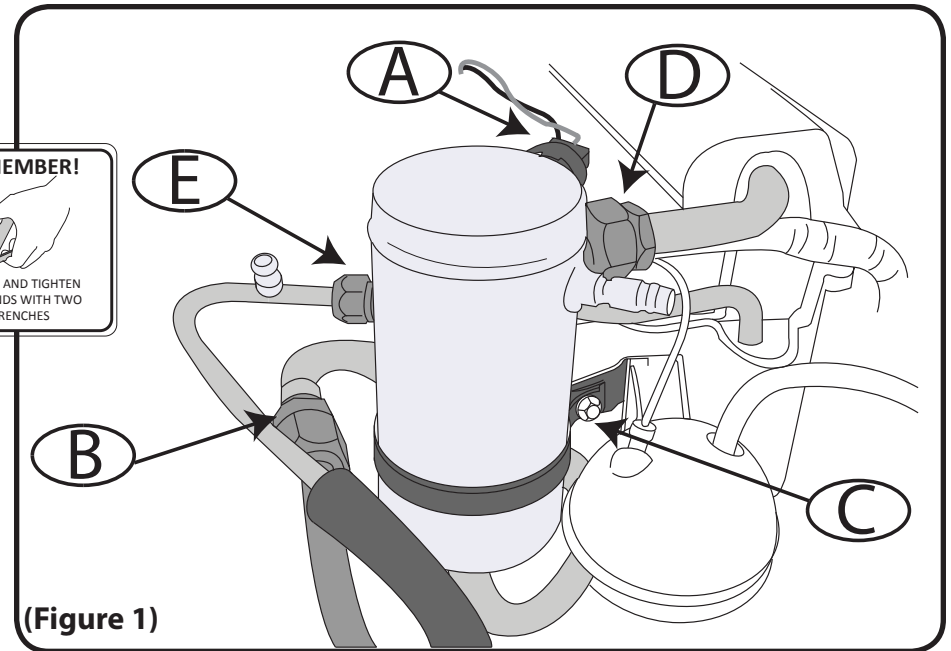

*Note the orientation of the orifice tube in the evaporator inlet, as the new tube will be installed in the same orientation. There is a tool made for removal of stuck orifice tubes, typically it can be carefully removed with a pair of needle nose pliers.*

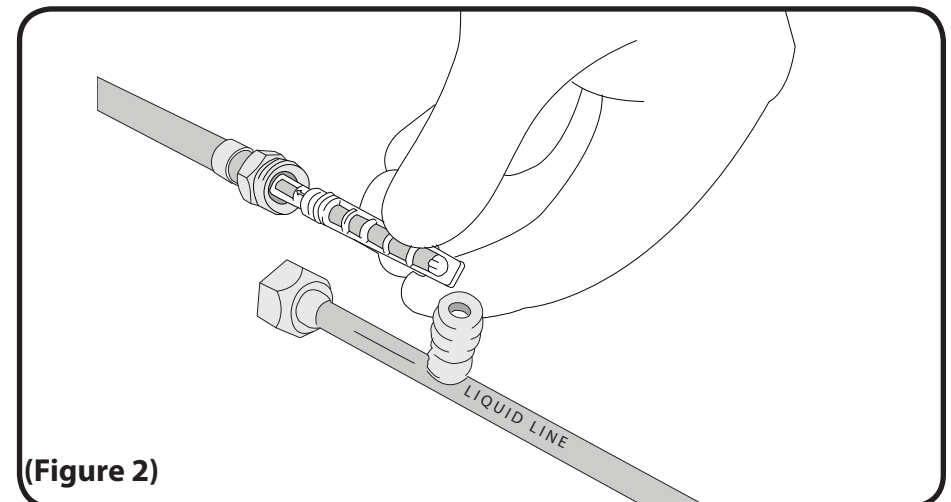

## COMPRESSOR REMOVAL

Compressor instructions below are specific for the later model R4 compressor, however the steps are similar to earlier models that have an early-style A6 compressor. Remove the A6 Compressor and all of its brackets as with the R4

- Remove electrical plugs from compressor, move to side for later connection. In addition, you will need to remove block mounted sensor wire that is routed through the compressor bracket. It can be re-attached after the new compressor is attached.
- Loosen smog pump and alternator tensioner bolts and remove belts
- Remove compressor tensioner bolts and remove compressor belt
- Disconnect Discharge hose, (hose from compressor to condenser) from condenser. **(Figure 3C)**
- Detach hose manifold from rear of OEM compressor, **(Figure 3A)** by removing the bolt in the center of the manifold. Remove hose assembly from vehicle. **(Be careful not drip remaining coolant on painted surfaces)**
- Remove long brace that attaches to the intake manifold stud. **(Figure 3B)**
- Remove Compressor from factory brackets by removing tensioner bolts and lower pivot bolt on the front and back of the compressor.
- Remove tensioner bolts from power steering brackets. Loosen pivot bolt on bottom of steering pump.
- Remove three remaining brackets from engine

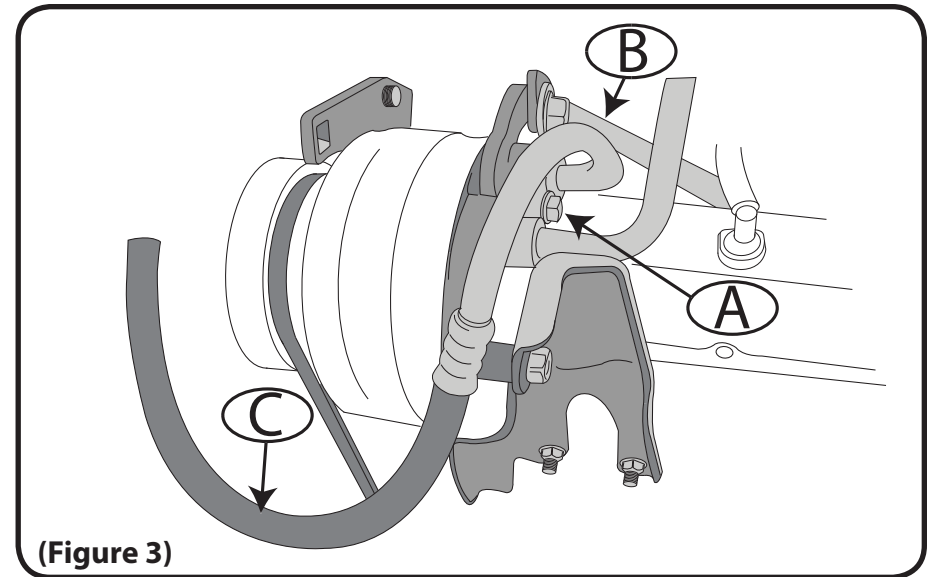



## COMPRESSOR INSTALLATION

This Kit and Bracket were designed as a replacement for factory parts. If your vehicle has been modified with items such as Tall Valve covers, you will need to refer to the compressor installation instructions from your included alternate bracket.

- Install the lower compressor mount to the head using (3x) 1" bolts and the (3x) 1/4" spacers. Spacers will mount between head and lower mount. **(Figure 4)**
- The left bracket bolt will fit through the factory power steering bracket, and then route through the new bracket and spacer. Now tighten the power steering pump and confirm belt has proper tension. **(Figure 4A)**
- Attach the upper compressor mount to the lower compressor mount using the (3x) 3/4" bolts with the lock washers and flat washers on top of the upper mount. **(Figure 5A)**  
**Attach loosely, as this upper plate will need to be moved for belt alignment in future steps**
- Attach the T-adjuster to the **B&F** (facing unit) of the compressor using the 5" bolt and nylock nut. **(Figure 6A) Do not tighten completely until later step.**  
**It is critical that the fill plug is mounted upwards once the compressor is mounted.**
- Place one of the T-adjuster 1/2" nuts on the adjuster to the end of the threads to allow for maximum adjustment.
- Align the compressor tabs **D&G** with the upper bracket fixed spacer. **(Figure 5C)** Attach using the 1" spacer at the rear of the fixed spacer using the 5" bolt and nylock nut. **(Figure 8B) Do not tighten completely until later step.**

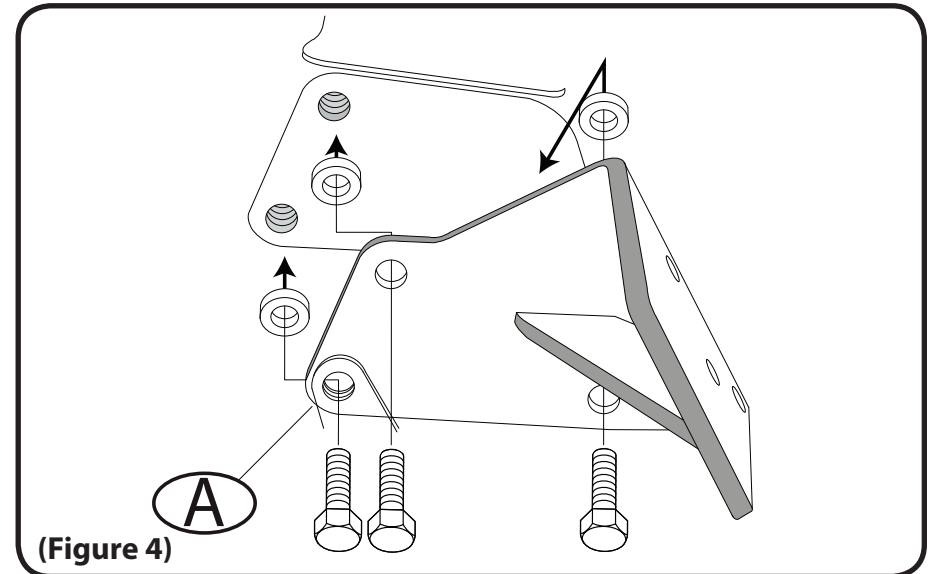

**(Figure 4)**

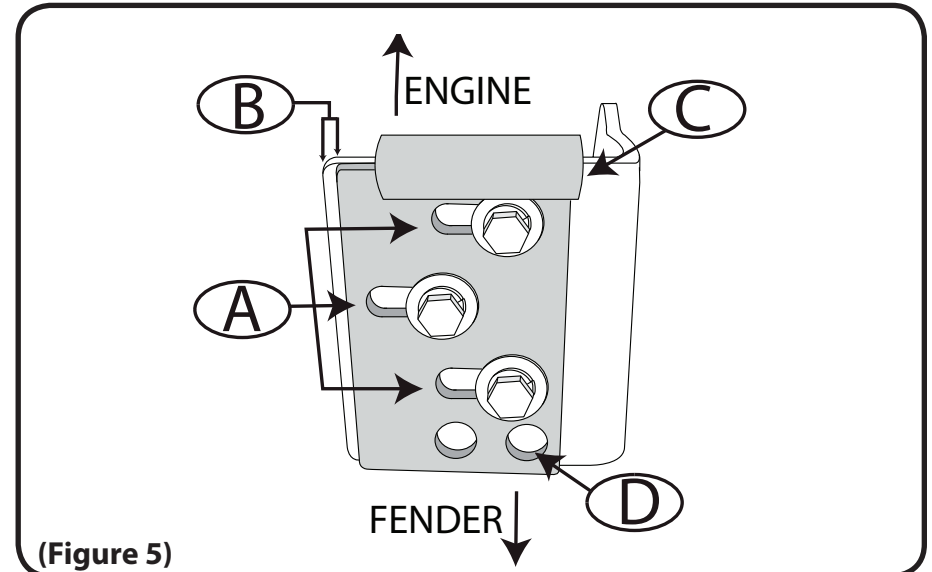

**(Figure 5)**



## COMPRESSOR INSTALLATION CONT.

- Lower the compressor and T-adjuster into the rear adjuster hole. **(Figure 5D, 6C)**
- Visually align the compressor pulley with the water pump pulley and the power steering pulley. Tighten one of the three 3/4" upper plate bolts.
- Raise the compressor, confirm that the leading edge of the upper and lower brackets are parallel. **(Figure 5B)** Tighten the remaining of the three bolts and lower compressor back into mount.
- Install the included belt, and then tension with the installed nut on the T-adjuster.
- Install the second 1/2" nut and lock washer to the bottom of the T-adjuster bolt to lock the compressor at the correctly tensioned setting.
- Tighten nylock nuts on 5" compressor mount bolts
- The compressor wire will need to be connected to the OEM wiring. Find the compressor wire that was originally connected to the OEM compressor and cut the connector off. Shave the insulation off the end of the green wire and crimp the female bullet connector, then connect the male bullet connector from the compressor.
- ***If the car was equipped with a switch mounted in the back of the compressor, it will be eliminated. Find the wiring and cut the connector off. Shave the insulation off the end of both wires and crimp together using the supplied butt connector. Place back in wire loom.***

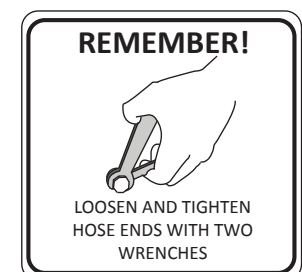
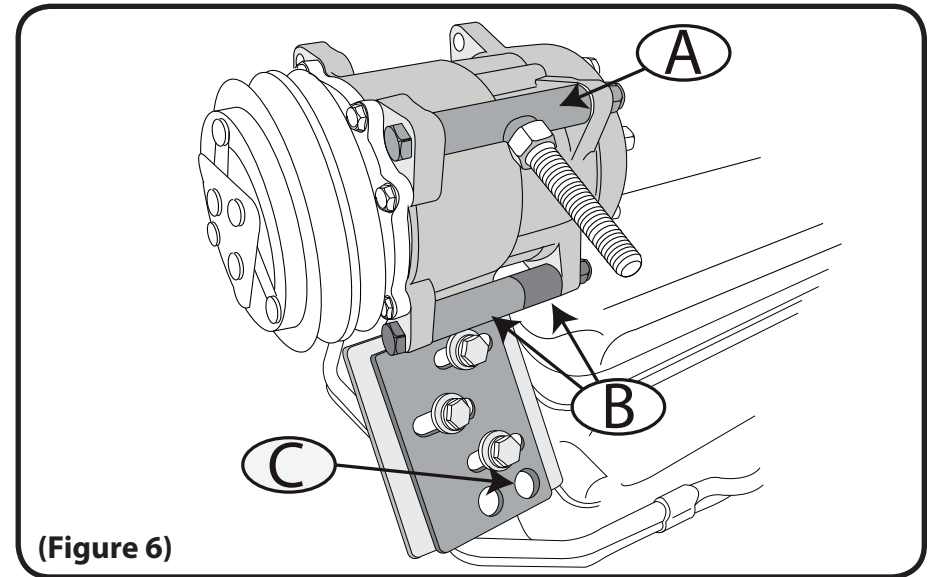



## ORIFICE TUBE/134A ADAPTER

- Install new orifice tube into evaporator inlet fitting with lubricated O-rings (**Figure 2**).
- With a Schrader valve removal tool, remove the Schrader valve from the liquid line. It will not be used with the 134a adapter.
- Screw the 134a adapter (Red Cap) onto the R12 port on the liquid line **without oil**, (*adapter has thread-lock on threads*).
- Attach the liquid line to the inlet fitting of the evaporator - It may be necessary to manipulate the line slightly to fit into place.

## ACCUMULATOR INSTALLATION

- Screw provided pressure cycling switch into the rear port on the top of the accumulator. (**Figure 7A**) \*See note at end of instructions - Page 10
- With a Schrader valve removal tool, remove the Schrader valve from the other accumulator port. It will not be used with the 134a adapter.
- Screw the 134a adapter (Blue Cap) onto the R12 port on the accumulator **without oil**, (*adapter has thread-lock on threads*).
- Slide the new accumulator into the brackets, but do not tighten screws until evaporator connection is complete.
- Tighten evaporator fitting with Lubricated O-ring to accumulator. (**Figure 7B**)

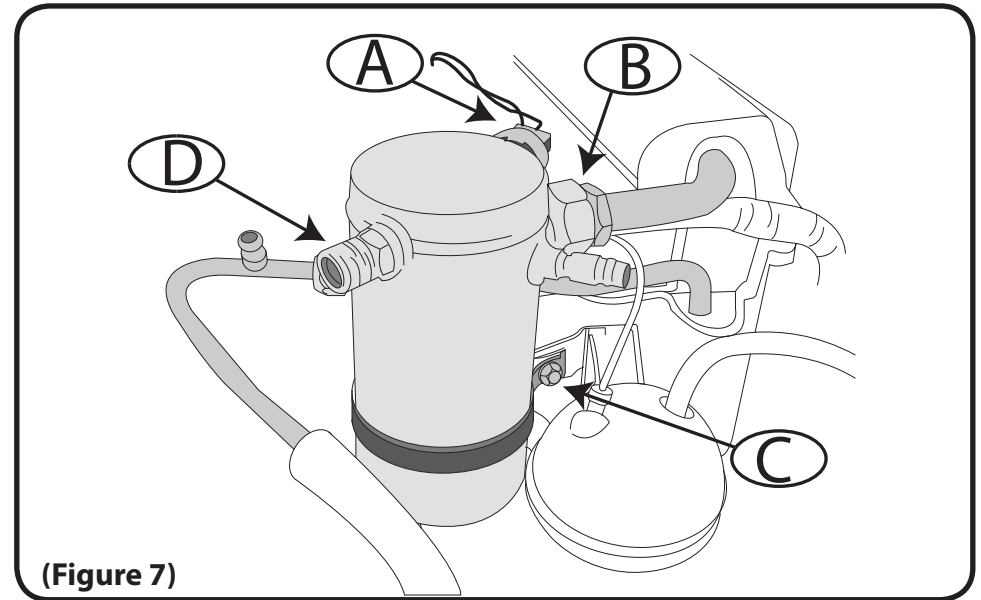

(Figure 7)

- Tighten the accumulator bracket screw, (**Figure 7C**) and small hose clamp to lower evaporator fitting. Fitting may need to be carefully manipulated to fit into clamp. (Outlet fitting of accumulator will be attached to suction hose in a later step)
- Plug the pressure cycling switch harness into the installed switch





## HOSE CONNECTION

- Loosely attach the Suction hose with lubricated O-Ring to the “S” port of the compressor and the other end to the accumulator fitting. **(Figure 8B)**
- Loosely attach the Discharge hose with lubricated O-Ring to the “D” port of the compressor and the other end to the inlet fitting of the condenser. **(Figure 8A)**
- After proper routing of the hoses and checking for clearance, tighten fittings on compressor. **(Figure 9)**

## FINAL STEPS

Take a look around at your installation and check all fittings and bolts for tightness, and make sure nothing is routed in a way to obstruct any moving parts. You can reconnect the battery at this time.

**PLEASE NOTE! IT'S CRITICAL THAT ALL COMPONENTS ARE CLEAN AND FREE OF CONTAMINATION. DAMAGE TO COMPONENTS AS A RESULT OF CONTAMINATION WILL NOT BE COVERED UNDER WARRANTY.**

*\* Pressure Cycling Switch Note:  
Your kit comes with an adjustable pressure cycling switch. Be sure to advise the charging technician this will need to be tuned to your vehicle and 134a requirements for proper cooling.*

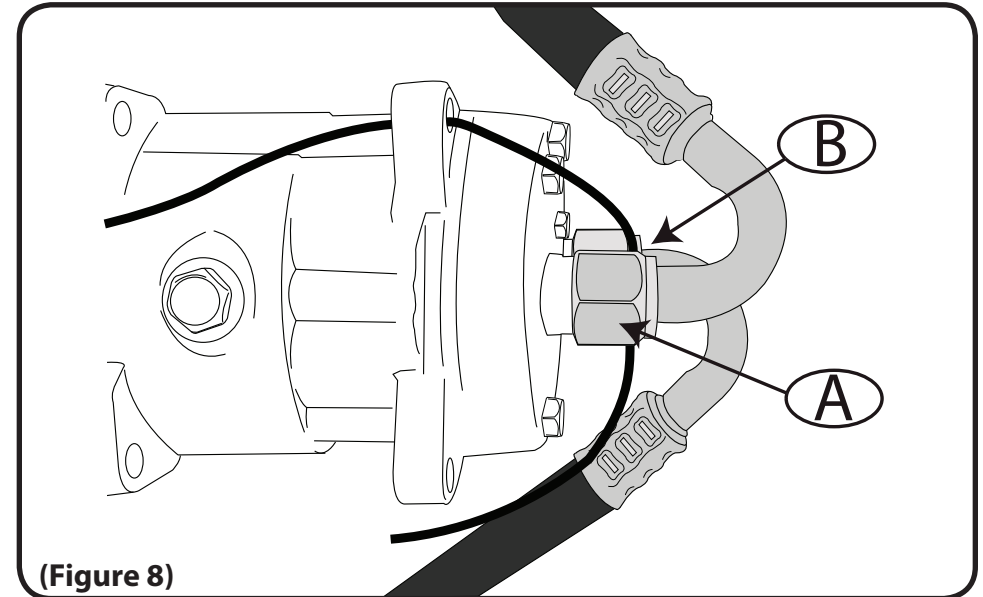

**(Figure 8)**

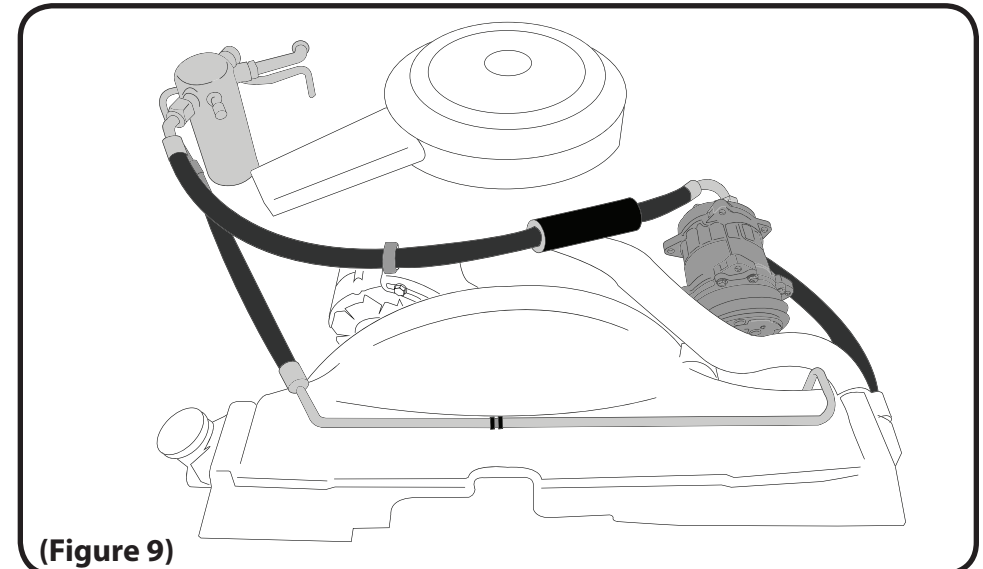

**(Figure 9)**